

RoHS Compliant & Pb Free Product

MC1-AM08A:

- Category: Amplifier
- Device Package: LP3
- Cell Size: Single (1x1)
- PCB Material/Layer Details: RO4350/2 layer with thickness 0.020"

Supported Device Package and Its Pin Allocation:

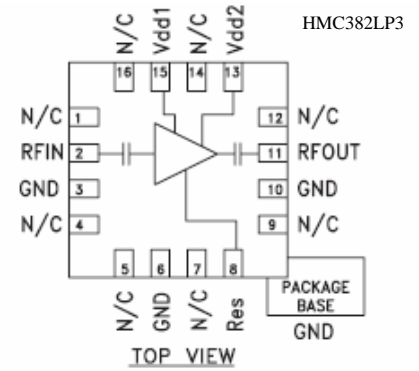
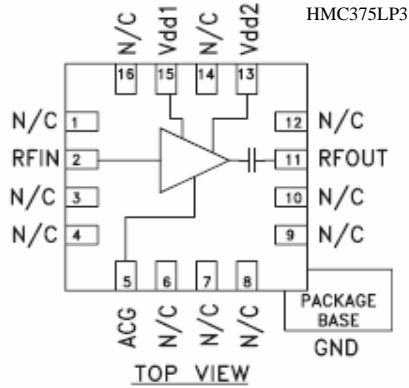
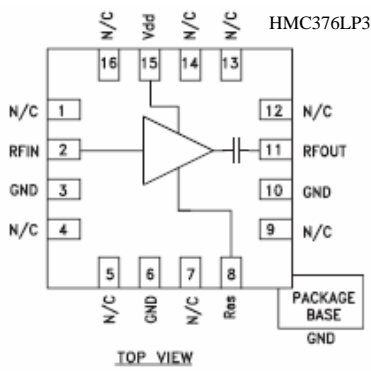

Schematic:

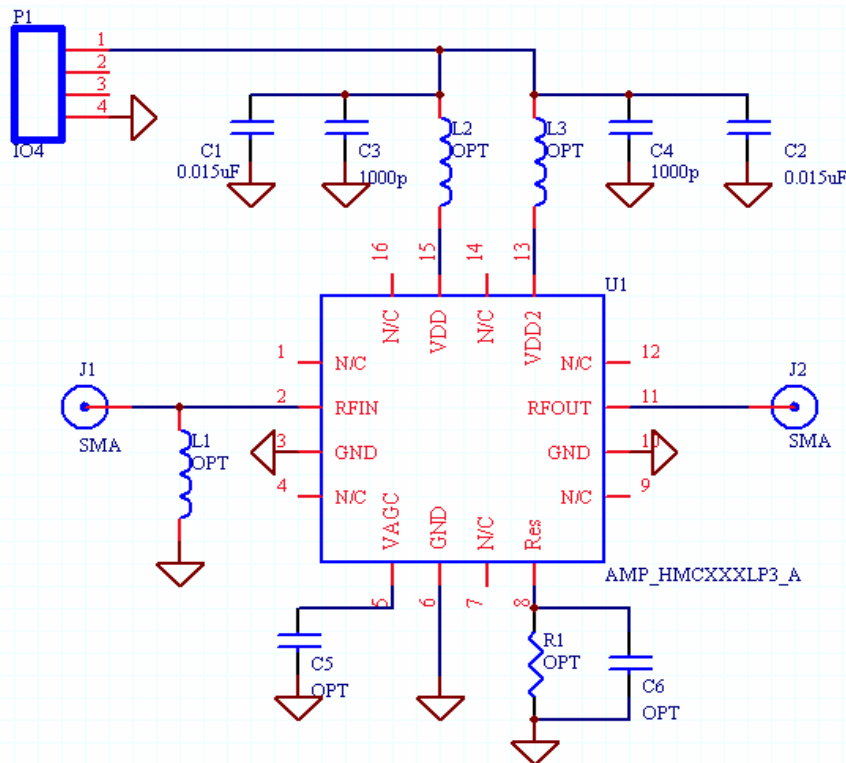

Option Table

	R1	C5	C6	L1	L2	L3
HMC375LP3	Neq	1000pF	Neq	13nH	33nH	24nH
HMC376LP3	Rbias	Neq	1000pF	47nH	18nH	Neq
HMC382LP3	Rbias	Neq	10pF	Neq	56nH	18nH

MC1-AM08A PCB Layout:

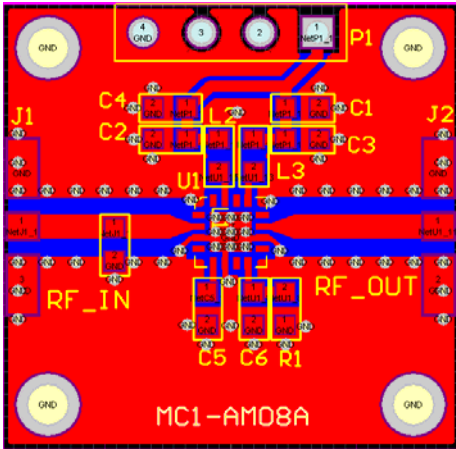

MC1-AM08A Assembly Drawing

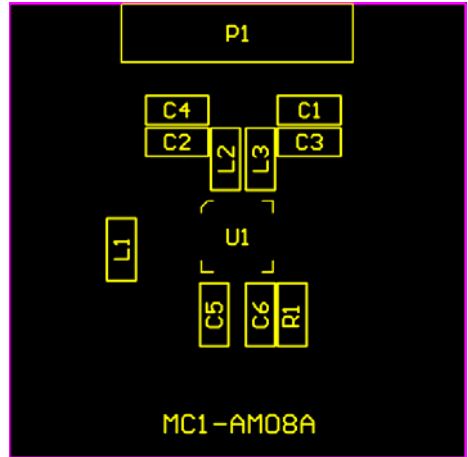

Minimum supported devices and its vendors:

Hittite
HMC375LP3
HMC376LP3
HMC382LP3

Bill of Material Example:

Used	Part Type	Designator	Footprint
2	0.015uF	C1 C2	0603
2	1000p	C3 C4	0603
1	AMP_HMCXXXLP3_A	U1	LP3
1	IO4	P1	P2_CON4_S
6	OPT	C5 C6 L1 L2 L3 R1	0603